

8.4" Industrial Open Frame TFT LCD Monitor

Industrial Application

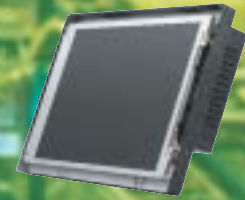

Where Versatility Meets Flexibility

K08AS-FA

Configuration		K08AS-FA
LCD Display		8.4" TFT active matrix panel
Pixel Pitch		0.213(H) x 0.213 (V) mm
Max. Resolution		SVGA 800 x 600
Contrast Ratio		350:1 (typical)
Brightness		220 Cd/m ² (typical)
Response Time (Tr+ Tf)		35 ms (typical)
Display Color		262K
Effective Display Area		170.4 (V) x 127.8 (H)
Viewing Angle (CR ≥ 10)		120° (H) x 100° (V)
Backlight		CCFL x 1
Lamp Life		20,000(hr)
Input Signals		Analogue VGA
Signal Connector	Analog	D-sub 15 pin (VGA)
	Digital	N/A
	Video-in	N/A
Scan Frequency		H. scan 31~38KHz, V. scan 56 ~ 75Hz
Speakers		N/A
USB HUB		N/A
Touch panel		Resistive - RS232 or USB A type (option)
Key Control		Power on/off with LED, Menu, Select, Adjustment (+, -)
Operating Condition	Temperature	0°C-50°C (32°F-122°F)
	Humidity	20%-80% (no condensation)
	Altitude	To 10,000 feet
Storage Condition	Temperature	-20°C-60°C (-4°F-140°F)
	Humidity	10%-90% (no condensation)
Power		Universal power adaptor Input AC 100~240V, 50~60Hz; Output DC 12V / 2A
Power Consumption		18W
Power Management		VESA DPMS Standard
Dimensions (WxHxD)		218 x 163 x 40.9 mm
Dimensions (Carton 2 in 1)		430 x 310 x 118 mm
Weight (Net)		1.8 Kg
Certification		FCC, CE

Features :

- * High contrast color TFT LCD open frame display support resolution up to SVGA 800 x 600 Compatible with IBM, VGA, VESA standards.
- * Flexible mechanical designs for industrial application.
- * Support DDC1/2B for Plug & Play compatibility.
- * Advanced OSD control for picture quality adjustment.
- * Industrial OSD foil.
- * Optional removable OSD pad.
- * Optional touch solutions.
- * Built-in Industrial Power Plug.
- * Hot key for AUTO adjustment.
- * Flexible Mounting Solutions - Front mounting, Rack mounting & VESA mounting.
- * Space reserved under I/O port.
- * Input power range 12V ~ 24V supported.



Optional Accessories :

- ELO 5-wire resistive touch panel.
- Higgstec 5 Wire resistive touch panel
- Anti-Glare tempered glass
- Customized touch solution acceptable.
- Front Mounting Frame.
- 19" Rack Mounting Frame.
- Removable OSD Pad

Ordering Information :

- K08AS-FA VGA only

* Specifications are subject to change without notice.

Mechanical drawing

I/O Ports

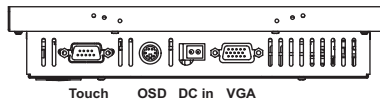

UNOT : mm

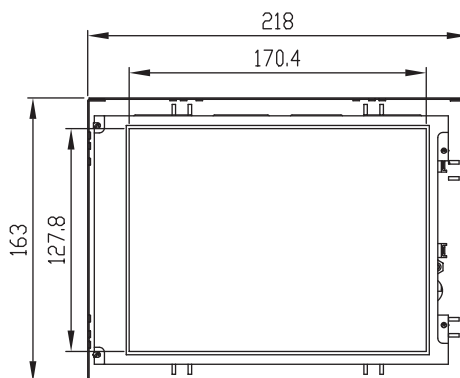

Front Side

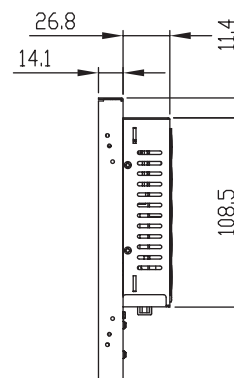

Back Side