

8.4" Industrial Chassis TFT LCD Monitor

Industrial Application



Where Versatility Meets Flexibility

K08AS-CA

| Configuration | | K08AS-CA |
|----------------------------|-------------|--|
| LCD Display | | 8.4" TFT active matrix panel |
| Pixel Pitch | | 0.213(H) x 0.213 (V) mm |
| Max. Resolution | | SVGA 800 x 600 |
| Contrast Ratio | | 350:1 (typical) |
| Brightness | | 220 Cd/m ² (typical) |
| Response Time (Tr+ Tf) | | 35 ms (typical) |
| Display Color | | 262K |
| Effective Display Area | | 170.4 (V) x 127.8 (H) |
| Viewing Angle (CR ≥ 10) | | 120° (H) x 100° (V) |
| Backlight | | CCFL x 1 |
| Lamp Life | | 20,000(hr) |
| Input Signals | | Analogue VGA |
| Signal Connector | Analog | D-sub 15 pin (VGA) |
| | Digital | N/A |
| | Video-in | N/A |
| Scan Frequency | | H. scan 31~38KHz, V. scan 56 ~ 75Hz |
| Speakers | | N/A |
| USB HUB | | N/A |
| Touch panel | | Resistive - RS232 or USB A type (option) |
| Key Control | | Power on/off with LED, Menu, Select, Adjustment (+, -) |
| Operating Condition | Temperature | 0°C-50°C (32°F-122°F) |
| | Humidity | 20%-80% (no condensation) |
| | Altitude | To 10,000 feet |
| Storage Condition | Temperature | -20°C-60°C (-4°F-140°F) |
| | Humidity | 10%-90% (no condensation) |
| Power | | Universal power adaptor Input AC 100~240V, 50~60Hz; Output DC 12V / 2A |
| Power Consumption | | 18W |
| Power Management | | VESA DPMS Standard |
| Dimensions (WxHxD) | | 220.0 x 165.0 x 41.8 mm |
| Dimensions (Carton 2 in 1) | | 430 x 310 x 118 mm |
| Weight (Net) | | 1.8 Kg |
| Certification | | FCC, CE |

Features :

- * Rugged metal chassis offering strong protection
- * High contrast color TFT LCD open frame display support resolution up to SVGA 800 x 600 Compatible with IBM, VGA, VESA standards.
- * Flexible mechanical designs for industrial applications.
- * Support DDC1/2B for Plug & Play compatibility.
- * Advanced OSD control for picture quality adjustment.
- * **Industrial OSD foil.**
- * Optional removable OSD pad.
- * Optional touch solutions.
- * **Built-in Industrial Power Plug.**
- * Hot key for AUTO adjustment.
- * **Flexible Mounting Solutions - Front Mounting, Rack Mounting & VESA Mounting.**
- * **Space reserved under I/O port.**
- * **Input power range 12V ~ 24V supported.**
- * **IP54 water resistant compliant. (Option)**



Optional Accessories :

- ELO 5-wire resistive touch panel.
- Higgstec 5 Wire resistive touch panel
- Anti-Glare tempered glass
- Customized touch solution acceptable.
- Front Mounting Frame.
- 19" Rack Mounting Frame.
- Removable OSD Pad

Ordering Information :

- K08AS-CA VGA only

* Specifications are subject to change without notice.

Mechanical drawing

I/O Ports

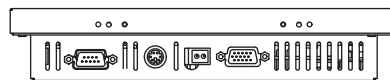

UNIT : mm

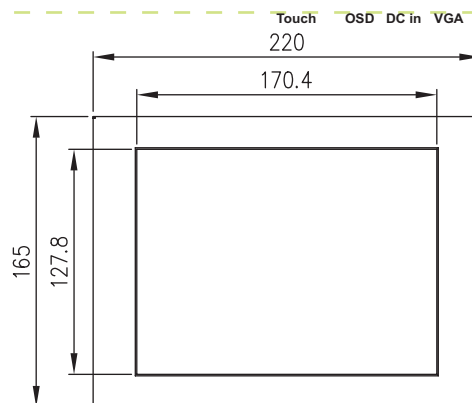

Front Side

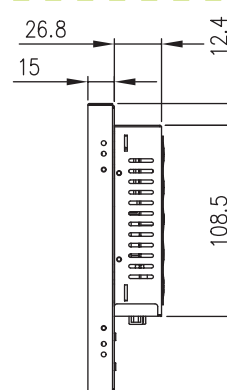

Back Side